

75F...SP 12 (ISO 인서트)

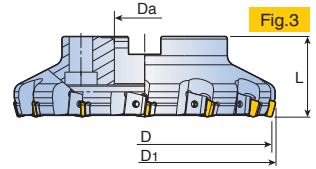

75° 페이스 밀

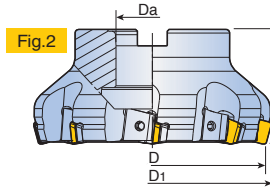
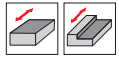
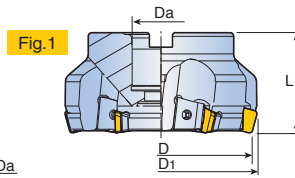
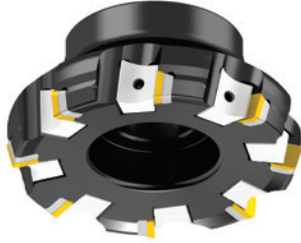

규격	인서트	⌀	치수(mm)				중량(Kg)	Fig.	장착부 볼트
			D	D1	Da	L			
75F-D80-25.4-SP12	SPKN 1203 EDR-HPN SPKN 1203 EDSR-EM SPKN 1203 EDSR-HPN SPKR 1203 EDR-EM	5	80	85.4	25.4	50	1.2	1	SH M12 X 1.75 X 35
75F-D100-31.75-SP12		6	100	105.4	31.75	55	1.8	1	LH M16 X 2 X 35
75F-D125-38.1-SP12		8	125	130.4	38.1	63	2.8	2	-
75F-D160-50.8-SP12		10	160	165.4	50.8	63	4.8	2	-
75F-D200-47.625-SP12		12	200	205.4	47.625	63	6.4	3	-
75F-D250-47.625-SP12		16	250	255.4	47.625	63	11.1	3	-
75F-D315-47.625-SP12		20	315	320.4	47.625	63	17.3	3	-

	부품				
	심	웬지	심 스크류	웬지 스크류	렌치
	DSSP 12N	DWPA 8	DS 40B100I-TS	DS 80200W-TS, *DS 80160W-TS	DTTW-4

* DS 80160W-TS: Ø80에만 적용 · 인서트 혼용 사용 금지

DMFN75...SP 12/15 (ISO 인서트)



75° 페이스 밀, 웻지 + 심 클램핑

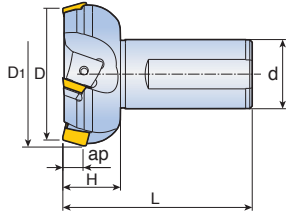
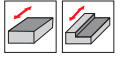

규격	인서트	✳	치수(mm)					
			D	D1	d	L	H	ap
DMFN75-D63-SP12	SPKN 1203 EDR-HPN	3	63	68.3	32	115	35	8
	SPKN 1203 EDSR-EM	3	63	68.3	32	115	35	8
	SPKN 1203 EDSR-HPN	3	63	68.3	32	115	35	8
	SPKR 1203 EDR-EM	3	63	68.3	32	115	35	8
DMFN75-D80-SP15	SPKN 1504 EDR-HPN	4	80	86.9	42	115	35	12
	SPKN 1504 EDSR-EM	4	80	86.9	42	115	35	12
	SPKN 1504 EDSR-HPN	4	80	86.9	42	115	35	12
	SPKR 1504 EDSR-EM	4	80	86.9	42	115	35	12

	부품				
	심	웻지	심 스크류	웻지 스크류	렌치
DMFN75-D63-SP12	DSSP 12N	DWPA 8	DS 40B100I-TS	DS 80200W-TS	DTTW-4
DMFN75-D80-SP15	DSSP 15N	DWPA 8	DS 40B100I-TS	DS 80160W-TS	DTTW-4

• 인서트 혼용 사용 금지

75F...SP 15 (ISO 인서트)



75° 페이스 밀

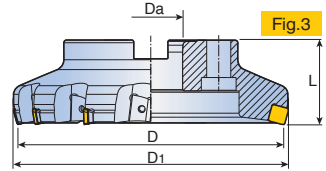
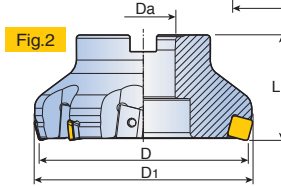
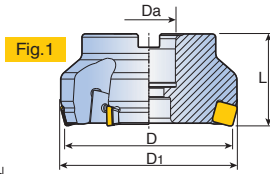
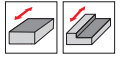

규격	인서트		치수(mm)				중량 (Kg)	Fig.	장착부 볼트	
			D	D1	Da	L				
75F-D80-25.4-SP15	SPKN 1504 EDR-HPN SPKN 1504 EDSR-EM SPKN 1504 EDSR-HPN SPKR 1504 EDSR-EM		5	80	87.0	25.4	55	1.3	1	SH M12 X 1.75 X 35
75F-D100-31.75-SP15			5	100	107.0	31.75	55	2.0	1	LH M16 X 2 X 35
75F-D125-38.1-SP15			8	125	132.0	38.1	63	2.7	2	-
75F-D160-50.8-SP15			10	160	166.9	50.8	63	4.7	2	-
75F-D200-47.625-SP15			12	200	206.9	47.625	63	6.4	3	-
75F-D250-47.625-SP15			16	250	256.9	47.625	63	10.8	3	-
75F-D315-47.625-SP15			20	315	321.9	47.625	63	17.9	3	-

	부품				
	심	웬지	심 스크류	웬지 스크류	렌치
	DSSP 15N	DWPA 8	DS 40B100I-TS	DS 80200W-TS, *DS 80160W-TS	DTTW-4

* DS 80160W-TS: Ø80에만 적용 • 인서트 혼용 사용 금지

75F...SN 12-N



75° 페이스 밀

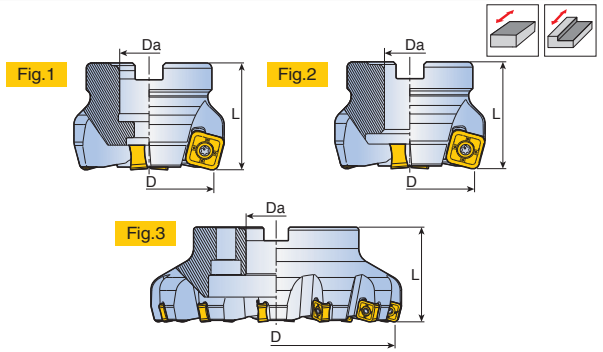
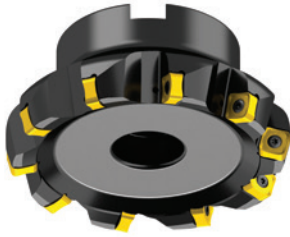

규격	인서트	⊕	치수(mm)			중량(Kg)	Fig.	장착부 볼트
			D	Da	L			
75F4-D40-22R-SN12-N	SNGU 1205 XTN SNKU 1205 XTN	4	40	22	40	0.3	1	LH M10X1.5X25
75F6-D50-22R-SN12-N		6	50	22	40	0.3	1	LH M10X1.5X25
75F6-D63-22R-SN12-N		6	63	22	40	0.5	1	LH M10X1.5X25
75F8-D63-22R-SN12-N		8	63	22	40	0.5	1	LH M10X1.5X25
75F7-D80-25.4R-SN12-N		7	80	25.4	50	1.3	1	LH M12X1.75X30
75F7-D80-27R-SN12-N		7	80	27	50	1.2	1	LH M12X1.75X30
75F9-D80-27R-SN12-N		9	80	27	50	1.2	1	LH M12X1.75X30
75F10-D80-25.4R-SN12-N		10	80	25.4	50	1.3	1	LH M12X1.75X30
75F10-D80-27R-SN12-N		10	80	27	50	1.2	1	LH M12X1.75X30
75F8-D100-31.75R-SN12-N		8	100	31.75	50	1.7	2	-
75F8-D100-32R-SN12-N		8	100	32	50	1.8	1	LH M16X2X35
75F8-D100-32L-SN12-N		8	100	32	50	1.9	1	LH M16X2X35
75F12-D100-31.75R-SN12-N		12	100	31.75	50	1.7	2	-
75F12-D100-32R-SN12-N		12	100	32	50	1.9	1	LH M16X2X35
75F10-D125-38.1R-SN12-N		10	125	38.1	63	2.9	2	-
75F10-D125-40R-SN12-N		10	125	40	63	3	1	SH M20X2.5X40
75F16-D125-31.8R-SN12-N		16	125	31.8	63	2.9	2	-
75F16-D125-40R-SN12-N		16	125	40	63	3	1	SH M20X2.5X40
75F12-D160-40R-SN12-N		12	160	40	63	4.6	3	-
75F12-D160-50.8R-SN12-N		12	160	50.8	63	4.8	2	-
75F20-D160-50.8R-SN12-N	20	160	50.8	63	4.8	2	-	
75F22-D200-60R-SN12-N	22	200	60	63	6.2	3	-	
75F19-D315-60R-SN12-N	19	315	60	63	18	3	-	

	부품	
	스크류	렌치
	 DS 40B100I-TS	 DTTW-15